



晶采光電科技股份有限公司  
AMPIRE CO., LTD.

# Specifications for LCD module

Customer	
Customer part no.	
Ampire part no.	AM-1024768Y7TZQW-ABH
Approved by	
Date	



- Preliminary Specification
- Approved Specification

**AMPIRE CO., LTD.**

**4F., No.116, Sec. 1, Xintai 5th Rd., Xizhi Dist., New Taipei  
City221, Taiwan (R.O.C.)**

**新北市汐止區新台五路一段 116 號 4 樓(東方科學園區 A 棟)**

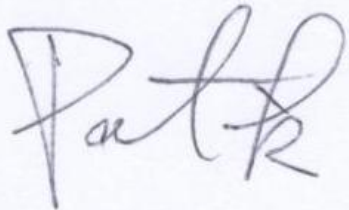
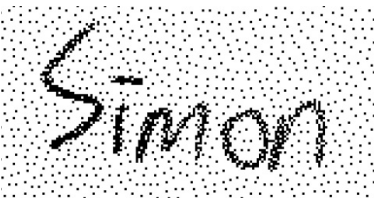
**TEL:886-2-26967269 , FAX:886-2-26967196 or 26967270**

Approved by	Checked by	Organized by
		

## RECORD OF REVISION

Revision Date	Page	Contents	Editor
2019/07/19	-	New Release	Jessica

# 1. General specification

AM-1024768Y7TZQW-ABH is a color active matrix thin film transistor (TFT) liquid crystal display (LCD) that uses amorphous silicon TFT as a switching device. This model is composed of a TFT LCD panel, a driving circuit and a back light system. This TFT LCD has a 10.4 inch diagonally measured active display area with HD (1024 horizontal by 768 vertical pixels) resolution.

- (1) Construction: 10.4" a-Si TFT active matrix, White LED Backlight.
- (2) Resolution (pixel): 1024(R.G.B) X 768
- (3) Number of the Colors : 16.2M (R , G , B 8 bit digital each)
- (4) LCD type : Normally black
- (5) Interface : 24 Bit LVDS interface

## 1.1 Display Characteristics

Item	Specification	Unit	
Number of Pixel	1024(H) x 768(V)	pixels	
Pixel pitch	0.20625(H) x 0.20625(V)	mm	
Pixel arrangement	RGB Vertical Stripe		
Display mode	Normally Black		
NTSC	70(Typ.)	%	
Weight	TBD	g	
Back-light	Single LED (Side-Light type)		
Power Consumption	Logic System (White Pattern)	TBD(max) @VDVDD=3.3V	W
	B/L System	TBD	W

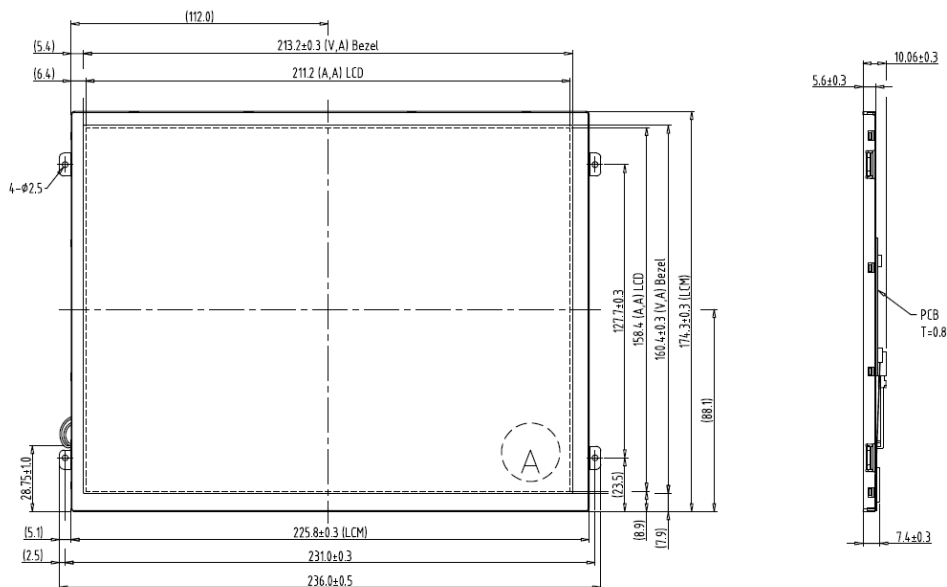

## 2. Optical Characteristics

Item		Symbol	Condition	Min.	Typ.	Max.	Unit	Note
Contrast		CR	$\Theta=0$ Normal viewing angle	600	900	—		(1)(2)
Response time	Rising	TR+TF		—	30	40	msec	(1)(3)
	Falling							
White luminance (Center)		YL		<b>480</b>	<b>600</b>	—	cd/m <sup>2</sup>	(1)(4) (IL=120mA)
Color chromaticity (CIE1931)	White	Wx		0.263	0.313	0.363		(1)(4)
		Wy		0.279	0.329	0.379		
	Red	Rx			TBD			
		Ry			TBD			
	Green	Gx			TBD			
		Gy			TBD			
	Blue	Bx		TBD				
		By		TBD				
Viewing angle	Hor.	$\Theta_L$	80	85	—			
		$\Theta_R$	80	85	—			
	Ver.	$\Theta_U$	80	85	—			
		$\Theta_D$	80	85	—			
Brightness uniformity		BUNI	$\Theta=0$	70	80	—	%	(5)
Optima View Direction		Free						(6)

### Measuring Condition

- Measuring surrounding : Dark room
- LED current IL : =120mA
- Ambient temperature : 25±2°C
- 15min. warm-up time.
- 

### Measuring Equipment

- FPM520 of Westar Display technologies, INC., which utilized SR-3 for Chromaticity and BM-5A for other optical characteristics.
- Measuring spot size : 20 ~ 21 mm

Note(1)

Definition of Viewing Angle:

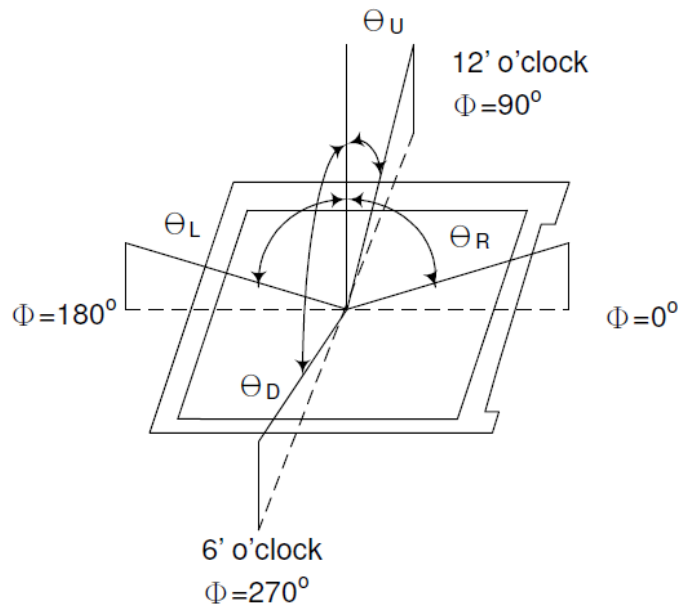

Note(2)

Definition of Contrast Ratio (CR) :  
measured at the center point of panel

$$CR = \frac{\text{Luminance with all pixels white}}{\text{Luminance with all pixels black}}$$

Note(3)

Definition of Response Time : Sum of  $T_R$  and  $T_F$

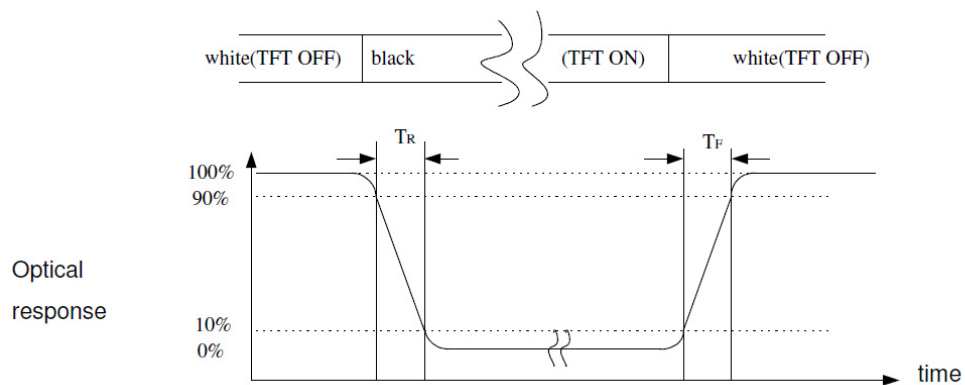

Note(4)

### Definition of optical measurement setup

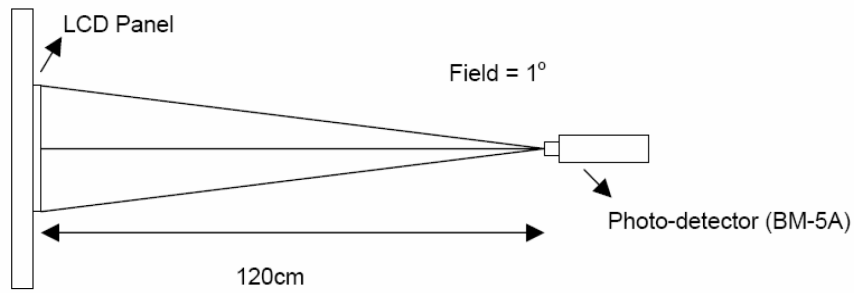

Note(5)

### Definition of brightness uniformity

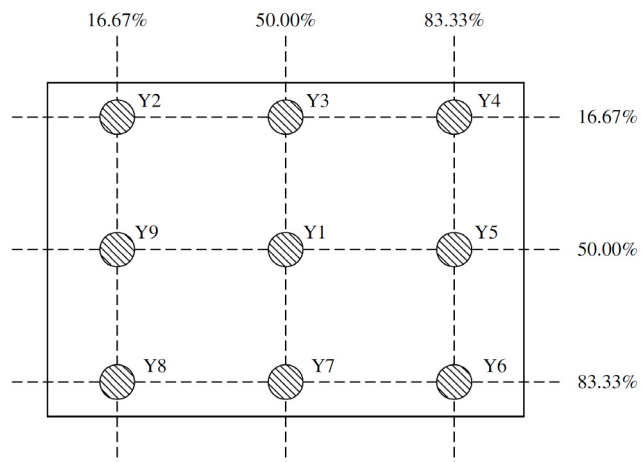

$$\text{Luminance uniformity} = \frac{(\text{Min Luminance of 9 points})}{(\text{Max Luminance of 9 points})} \times 100\%$$

Note(6) Rubbing direction (the different rubbing direction will cause the different optima view direction).

### 3. Functional Block Diagram

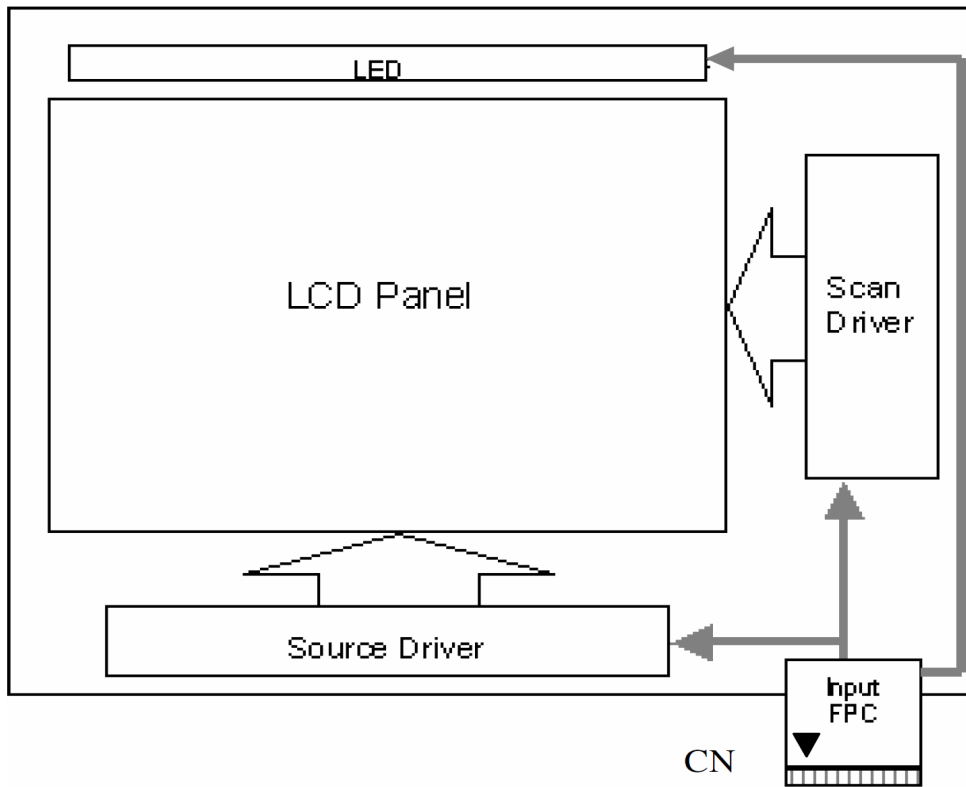

### Pixel Format

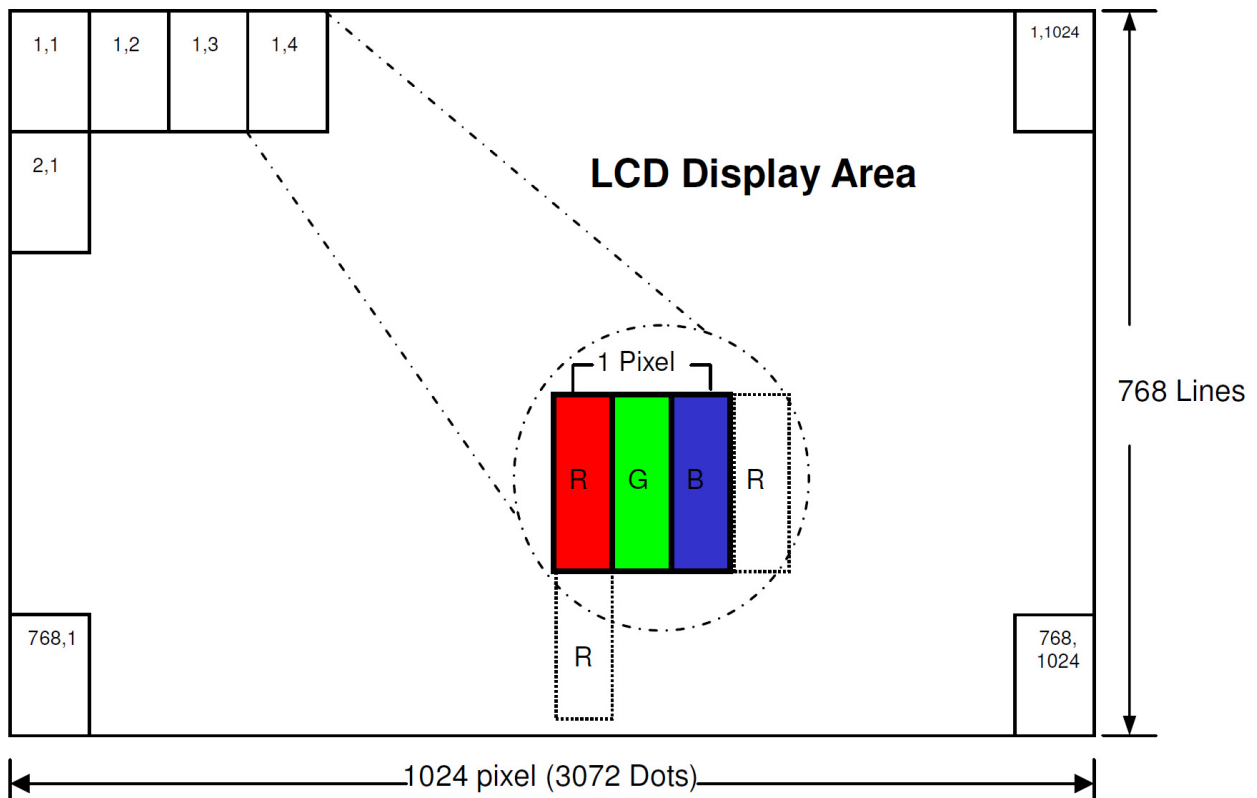

### 3.1 Relationship between Displayed Color and Input

	Display	MSB				LSB				MSB				LSB				Gray scale Level								
		R7	R6	R5	R4	R3	R2	R1	R0	G7	G6	G5	G4	G3	G2	G1	G0		B7	B6	B5	B4	B3	B2	B1	B0
Basic color	Black	L	L	L	L	L	L	L	L	L	L	L	L	L	L	L	L	L	L	L	L	L	L	L	L	-
	Blue	L	L	L	L	L	L	L	L	L	L	L	L	L	L	L	L	H	H	H	H	H	H	H	H	-
	Green	L	L	L	L	L	L	L	L	H	H	H	H	H	H	H	H	L	L	L	L	L	L	L	L	-
	Light Blue	L	L	L	L	L	L	L	L	H	H	H	H	H	H	H	H	H	H	H	H	H	H	H	H	-
	Red	H	H	H	H	H	H	H	H	L	L	L	L	L	L	L	L	L	L	L	L	L	L	L	L	-
	Purple	H	H	H	H	H	H	H	H	L	L	L	L	L	L	L	L	H	H	H	H	H	H	H	H	-
	Yellow	H	H	H	H	H	H	H	H	H	H	H	H	H	H	H	H	L	L	L	L	L	L	L	L	-
	White	H	H	H	H	H	H	H	H	H	H	H	H	H	H	H	H	H	H	H	H	H	H	H	H	-
Gray scale of Red	Black	L	L	L	L	L	L	L	L	L	L	L	L	L	L	L	L	L	L	L	L	L	L	L	L	L0
	Dark ↑ ↓ Light	L	L	L	L	L	L	L	H	L	L	L	L	L	L	L	L	L	L	L	L	L	L	L	L	L1
		L	L	L	L	L	L	H	L	L	L	L	L	L	L	L	L	L	L	L	L	L	L	L	L	L2
		:	:	:	:	:	:	:	:	:	:	:	:	:	:	:	:	:	:	:	:	:	:	:	:	L3...L251
		H	H	H	H	H	H	L	L	L	L	L	L	L	L	L	L	L	L	L	L	L	L	L	L	L252
	H	H	H	H	H	H	L	H	L	L	L	L	L	L	L	L	L	L	L	L	L	L	L	L	L253	
	H	H	H	H	H	H	H	L	L	L	L	L	L	L	L	L	L	L	L	L	L	L	L	L	L254	
Red	H	H	H	H	H	H	H	H	L	L	L	L	L	L	L	L	L	L	L	L	L	L	L	L	Red L255	
Gray scale of Green	Black	L	L	L	L	L	L	L	L	L	L	L	L	L	L	L	L	L	L	L	L	L	L	L	L	L0
	Dark ↑ ↓ Light	L	L	L	L	L	L	L	L	L	L	L	L	L	L	L	H	L	L	L	L	L	L	L	L	L1
		L	L	L	L	L	L	L	L	L	L	L	L	L	L	H	L	L	L	L	L	L	L	L	L	L2
		:	:	:	:	:	:	:	:	:	:	:	:	:	:	:	:	:	:	:	:	:	:	:	:	L3...L251
		L	L	L	L	L	L	L	L	H	H	H	H	H	H	L	L	L	L	L	L	L	L	L	L	L252
	L	L	L	L	L	L	L	L	H	H	H	H	H	L	H	L	L	L	L	L	L	L	L	L253		
	L	L	L	L	L	L	L	L	H	H	H	H	H	H	L	L	L	L	L	L	L	L	L	L254		
Green	L	L	L	L	L	L	L	L	H	H	H	H	H	H	H	H	L	L	L	L	L	L	L	L	Green L255	
Gray scale of Blue	Black	L	L	L	L	L	L	L	L	L	L	L	L	L	L	L	L	L	L	L	L	L	L	L	L	L0
	Dark ↑ ↓ Light	L	L	L	L	L	L	L	L	L	L	L	L	L	L	L	L	L	L	L	L	L	L	L	H	L1
		L	L	L	L	L	L	L	L	L	L	L	L	L	L	L	L	L	L	L	L	L	L	H	L	L2
		:	:	:	:	:	:	:	:	:	:	:	:	:	:	:	:	:	:	:	:	:	:	:	:	L3...L251
		L	L	L	L	L	L	L	L	L	L	L	L	L	L	L	L	H	H	H	H	H	H	L	L	L252
	L	L	L	L	L	L	L	L	L	L	L	L	L	L	L	L	H	H	H	H	H	H	L	H	L253	
	L	L	L	L	L	L	L	L	L	L	L	L	L	L	L	L	H	H	H	H	H	H	H	L	L254	
Blue	L	L	L	L	L	L	L	L	L	L	L	L	L	L	L	L	H	H	H	H	H	H	H	H	Blue L255	
Gray scale of White & Black	Black	L	L	L	L	L	L	L	L	L	L	L	L	L	L	L	L	L	L	L	L	L	L	L	L	L0
	Dark ↑ ↓ Light	L	L	L	L	L	L	L	H	L	L	L	L	L	L	L	H	L	L	L	L	L	L	L	H	L1
		L	L	L	L	L	L	H	L	L	L	L	L	L	H	L	L	L	L	L	L	L	H	L	L2	
		:	:	:	:	:	:	:	:	:	:	:	:	:	:	:	:	:	:	:	:	:	:	:	:	L3...L251
		H	H	H	H	H	L	L	H	H	H	H	H	L	L	H	H	H	H	H	L	L	L	L	L252	
	H	H	H	H	H	L	H	H	H	H	H	L	H	H	H	H	H	L	H	L	L	L253				
	H	H	H	H	H	H	L	H	H	H	H	H	L	H	H	H	H	H	L	L	L	L254				
White	H	H	H	H	H	H	H	H	H	H	H	H	H	H	H	H	H	H	H	H	H	H	H	H	White L255	



## 4. Absolute Maximum Ratings

### 4.1 Absolute Ratings of TFT LCD Module

Item	Symbol	Min.	Max.	Unit	Note
Power supply voltage	VDD	-0.3	5	V	
Logic Signal Input Level	VDVDD VDVDD_LVDS	-0.3	5	V	

### 4.2 Absolute Ratings of Environment

Item	Symbol	Min.	Max.	Unit	Note
Operating Temperature	T <sub>opa</sub>	-20	70	°C	
Storage Temperature	T <sub>stg</sub>	-30	80	°C	



## 5.2 Switching Characteristics for LVDS Receiver

Item	Symbol	Min.	Typ.	Max.	Unit	Conditions
Differential Input High Threshold	V <sub>th</sub>			100	mV	V <sub>CM</sub> =1.2V
Differential Input Low Threshold	V <sub>tl</sub>	-100			mV	
Input Current	I <sub>IN</sub>	-10		10	uA	
Differential input Voltage	V <sub>ID</sub>	0.1		0.6	V	
Common Mode Voltage Offset	V <sub>CM</sub>	0.7	1.2	1.6	V	

## 5.3 Bit LVDS input

### 5.1.1 8Bit LVDS input

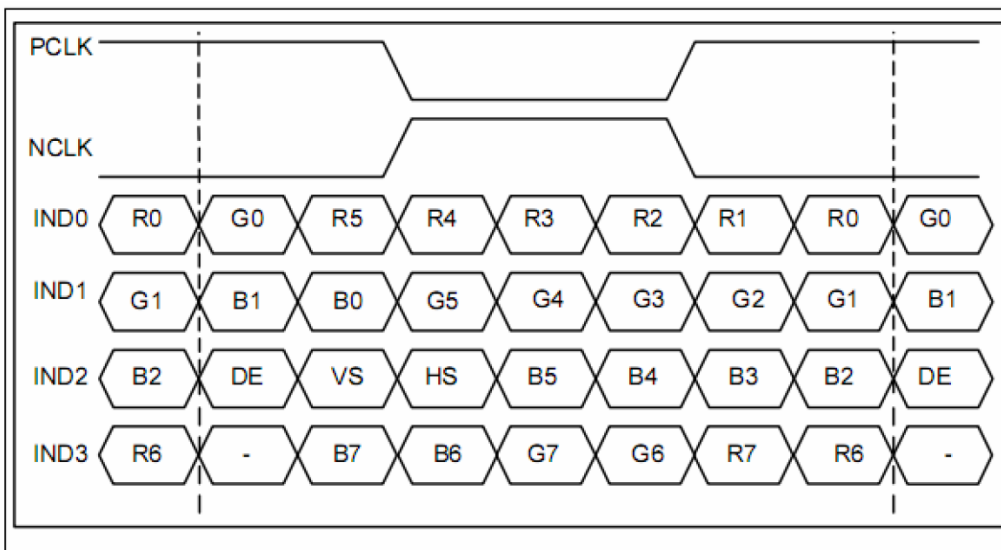

## 5.4 Interface Timing (DE mode)

DE mode					
Parameter	Symbol	Value			Unit
		Min.	Typ.	Max.	
DCLK frequency @Frame rate=60hz	fclk	52	65	71	Mhz
Horizontal display area	thd	1024			DCLK
HSYNC period time	th	1114	1344	1400	DCLK
HSYNC blanking	thb+thfp	90	320	376	DCLK
Vertical display area	tvd	768			H
VSYNC period time	tv	778	806	845	H
VSYNC blanking	tvb+tvfp	10	38	77	H

### Timing Diagram of Interface Signal (DE mode)

#### (1). Vertical input timing

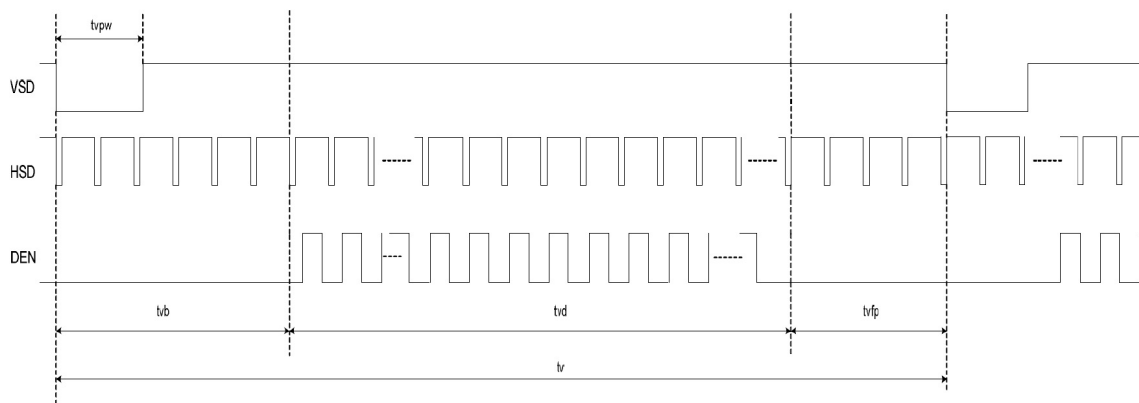

#### (2). Horizontal input timing

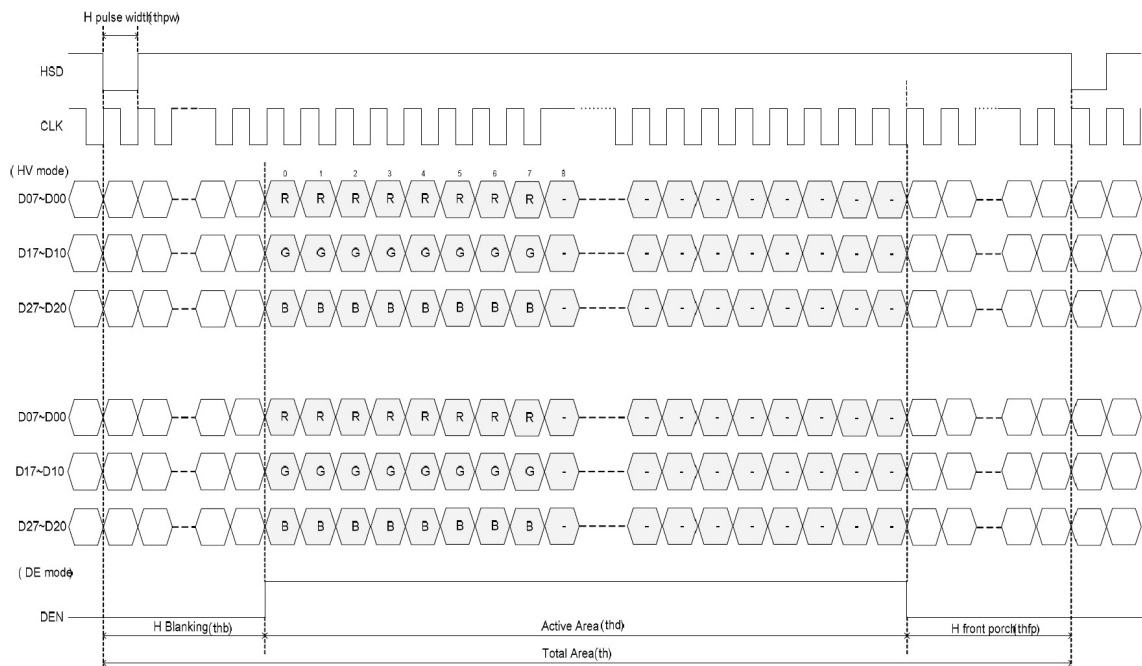

## 5.5 Power On / Off Sequence

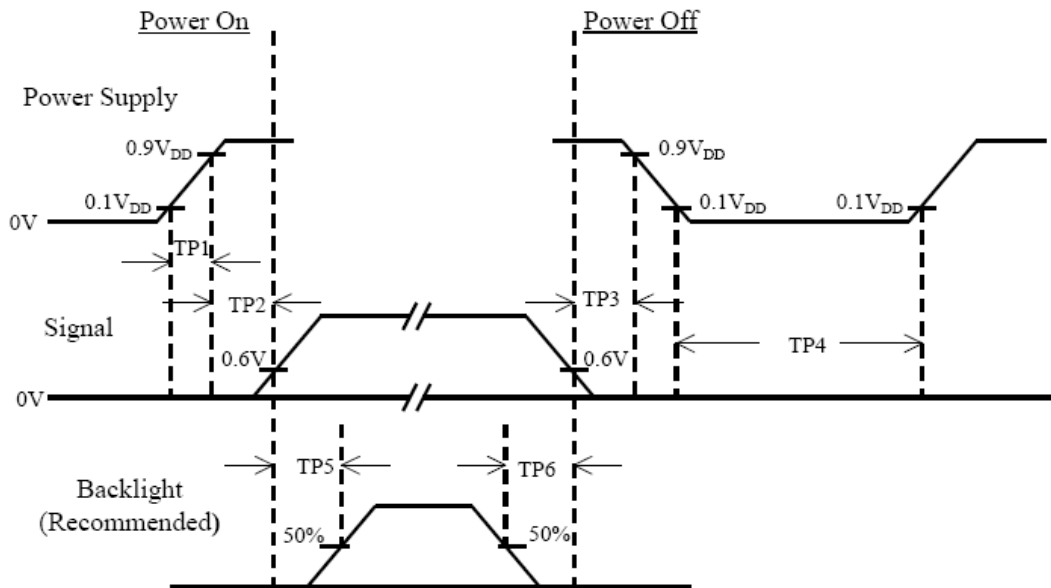

Item	Min.	Typ.	Max.	Unit	Remark
TP1	0.5	--	10	msec	
TP2	0	--	50	msec	
TP3	0	--	50	msec	
TP4	500	--	--	msec	
TP5	200	--	--	msec	
TP6	200	--	--	msec	

Note(1) The supply voltage of the external system for the module input should be the same as the definition of VDD.

Note(2) Apply the lamp voltage within the LCD operation range. When the back-light turns on before the LCD operation or the LCD turns off before the back-light turns off, the display may momentarily become white.

Note(3) In case of VDD = off level, please keep the level of input signal on the low or keep a high impedance.

Note(4) TP4 should be measured after the module has been fully discharged between power off and on period.

Note(5) Interface signal shall not be kept at high impedance when the power is on.

## 5.6 Backlight Unit

Parameter	Symbol	Min.	Typ.	Max.	Units	Condition
LED Current	IL	--	120	--	mA	Ta=25°C
LED Voltage	VL	--	33		Volt	Ta=25°C
LED Life-Time	N/A	50K	--	--	Hour	Ta=25°C Note (2)

Note(1) LED life time (Hrs.) can be defined as the time in which it continues to operate under the condition: Ta=25±3°C, typical IL value indicated in the above table until the brightness becomes less than 50%.

Note(2) The “LED life time” is defined as the module brightness decrease to 50% original brightness at Ta=25°C and IL=120mA. The LED lifetime could be decreased if operating IL is larger than 120mA. The constant current driving method is suggested.

Note(3) LED Light Bar Circuit is 11S2P.

Note(4) When LCM is operated over 40°C ambient temperature, the IL should be follow :

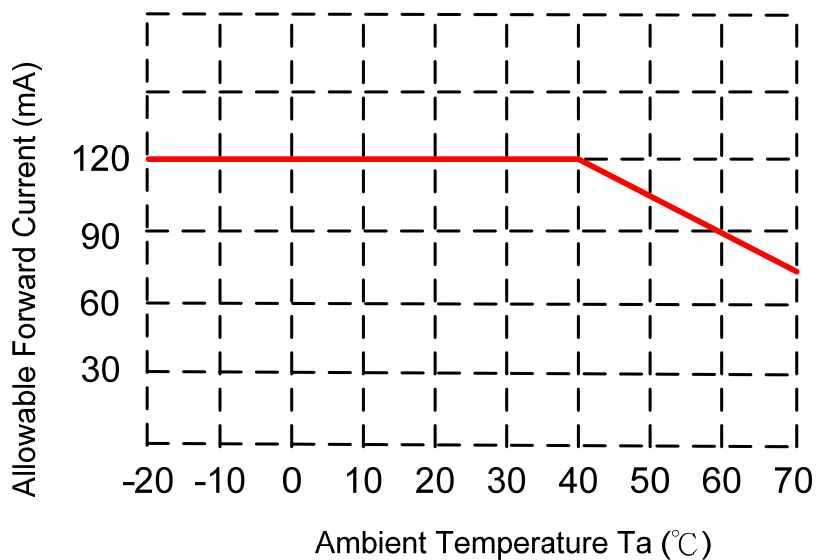

## 6. Interface Pin Connection

LVDS connector: P1.0 20pin/CP100-S20G-H16

Pin No.	Symbol	I/O	Description	Note
1	VDD	P	Power Voltage for Logic: 3.3V	
2	VDD	P	Power Voltage for Logic: 3.3V	
3	GND	P	Ground	
4	GND	P	Ground	
5	IN0-	I	- LVDS differential data input	
6	IN0+	I	+ LVDS differential data input	
7	GND	P	Ground	
8	IN1-	I	- LVDS differential data input	
9	IN1+	I	+ LVDS differential data input	
10	GND	P	Ground	
11	IN2-	I	- LVDS differential data input	
12	IN2+	I	+ LVDS differential data input	
13	GND	P	Ground	
14	CLK-	I	- LVDS differential data input	
15	CLK+	I	+ LVDS differential data input	
16	GND	P	Ground	
17	IN3-	I	- LVDS differential data input	
18	IN3+	I	+ LVDS differential data input	
19	VLED	P	Power Supply Voltage for LED Driver.	
20	ADJ	I	LED Back-light Brightness Adjust	

## 7. Reliability Test Criteria

Test Item	Test Conditions	Note
High Temperature Operation	70±3°C , t=240 hrs	
Low Temperature Operation	-20±3°C , t=240 hrs	
High Temperature Storage	80±3°C , t=240 hrs	1,2
Low Temperature Storage	-30±3°C , t=240 hrs	1,2
Storage at High Temperature and Humidity	60°C, 90% RH , 240 hrs	1,2
Thermal Shock Test	-20°C (30min) ~ 70°C (30min) 100 cycles	1,2
Vibration Test (Packing)	Sweep frequency : 10 ~ 55 ~ 10 Hz/1min Amplitude : 0.75mm Test direction : X.Y.Z/3 axis Duration : 30min/each axis	2

Note(1) Condensation of water is not permitted on the module.

Note(2) The module should be inspected after 1 hour storage in normal conditions (15-35°C, 45-65%RH)

Note(3) The module shouldn't be tested over one condition, and all the tests are independent.

Note(4) All reliability tests should be done without the protective film.

Definitions of life end point:

- Current drain should be smaller than the specific value.
- Function of the module should be maintained.
- Appearance and display quality should not have degraded noticeably.
- Contrast ratio should be greater than 50% of the initial value.



## **8. Use Precautions**

### **8.1 Handling precautions**

- (1) The polarizing plate may break easily so be careful when handling it. Do not touch, press or rub it with a hard-material tool like tweezers.
- (2) Do not touch the polarizing plate surface with bare hands so as not to make it dirty. If the surface or other related part of the polarizing plate is dirty, soak a soft cotton cloth or chamois leather in benzine and wipe off with it. Do not use chemical liquids such as acetone, toluene and isopropyl alcohol. Failure to do so may bring chemical reaction phenomena and deteriorations.
- (3) Remove any spit or water immediately. If it is left for hours, the suffered part may deform or decolorize.
- (4) If the LCD element breaks and any LC stuff leaks, do not suck or lick it. Also if LC stuff is stuck on your skin or clothing, wash thoroughly with soap and water immediately.

### **8.2 Installing precautions**

- (1) The PCB has many ICs that may be damaged easily by static electricity. To prevent breaking by static electricity from the human body and clothing, earth the human body properly using the high resistance and discharge static electricity during the operation. In this case, however, the resistance value should be approx.  $1M\Omega$  and the resistance should be placed near the human body rather than the ground surface. When the indoor space is dry, static electricity may occur easily so be careful. We recommend the indoor space should be kept with humidity of 60% or more. When a soldering iron or other similar tool is used for assembly, be sure to earth it.
- (2) When installing the module and ICs, do not bend or twist them. Failure to do so may crack LC element and cause circuit failure.
- (3) To protect LC element, especially polarizing plate, use a transparent protective plate (e.g., acrylic plate, glass etc.) for the product case.
- (4) Do not use an adhesive like a both-side adhesive tape to make LCD surface (polarizing plate) and product case stick together. Failure to do so may cause the polarizing plate to peel off.

### 8.3 Storage precautions

- (1) Avoid a high temperature and humidity area. Keep the temperature between 0°C and 35°C and also the humidity under 60%.
- (2) Choose the dark spaces where the product is not exposed to direct sunlight or fluorescent light.
- (3) Store the products as they are put in the boxes provided from us or in the same conditions as we recommend.

### 8.4 Operating precautions

- (1) Do not boost the applied drive voltage abnormally. Failure to do so may break ICs. When applying power voltage, check the electrical features beforehand and be careful. Always turn off the power to the LC module controller before removing or inserting the LC module input connector. If the input connector is removed or inserted while the power is turned on, the LC module internal circuit may break.
- (2) The display response may be late if the operating temperature is under the normal standard, and the display may be out of order if it is above the normal standard. But this is not a failure; this will be restored if it is within the normal standard.
- (3) The LCD contrast varies depending on the visual angle, ambient temperature, power voltage etc. Obtain the optimum contrast by adjusting the LC drive voltage.
- (4) When carrying out the test, do not take the module out of the low-temperature space suddenly. Failure to do so will cause the module condensing, leading to malfunctions.
- (5) Make certain that each signal noise level is within the standard (L level: 0.2V<sub>dd</sub> or less and H level: 0.8V<sub>dd</sub> or more) even if the module has functioned properly. If it is beyond the standard, the module may often malfunction. In addition, always connect the module when making noise level measurements.
- (6) The CMOS ICs are incorporated in the module and the pull-up and pull-down function is not adopted for the input so avoid putting the input signal open while the power is ON.
- (7) The characteristic of the semiconductor element changes when it is exposed to light emissions, therefore ICs on the LCD may malfunction if they receive light emissions. To prevent these malfunctions, design and assemble ICs so that they are shielded from light emissions.
- (8) Crosstalk occurs because of characteristics of the LCD. In general, crosstalk occurs when the regularized display is maintained. Also, crosstalk is affected by the LC drive voltage. Design the contents of the display, considering crosstalk.

### 8.5 Mechanical

- (1) Please hold the LCD module properly when you use or store it.

## 8.6 Other

- (1) Do not disassemble or take the LC module into pieces. The LC modules once disassembled or taken into pieces are not the guarantee articles.
- (2) Do not keep the LCD at the same display pattern continually. The residual image will happen and it will damage the LCD. Please use screen saver.
- (3) AMIPRE will provide one year warranty for all products and three months warrantee for all repairing products.

# 9. Outline Dimension

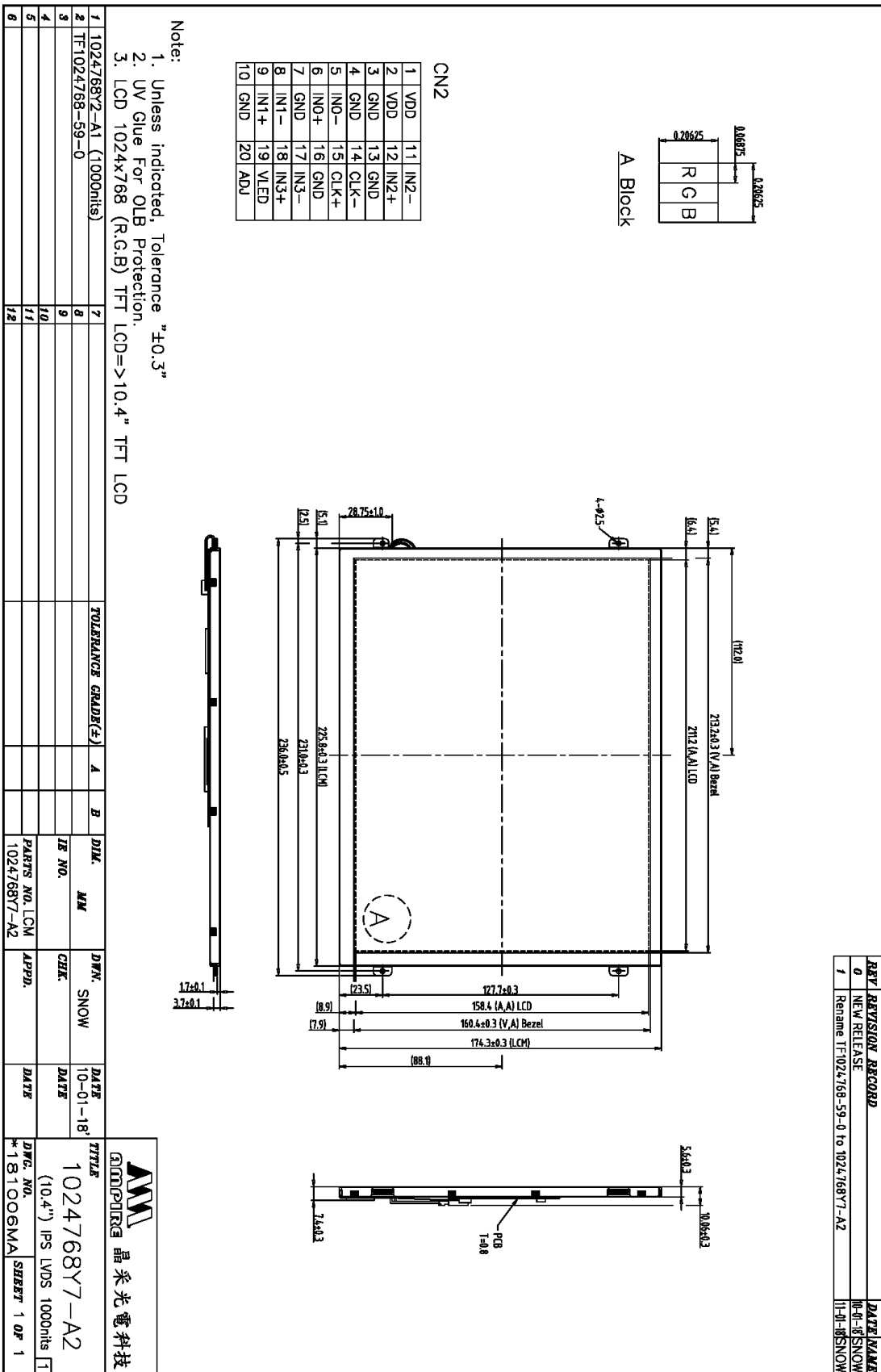



# 10. Package

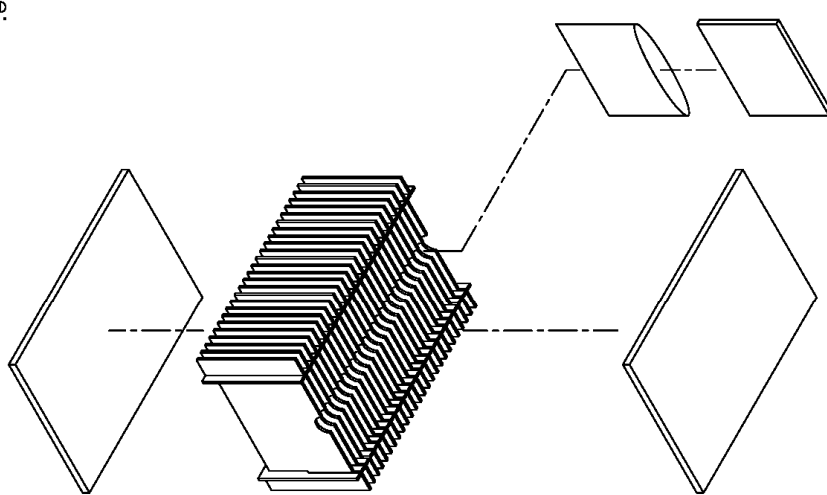

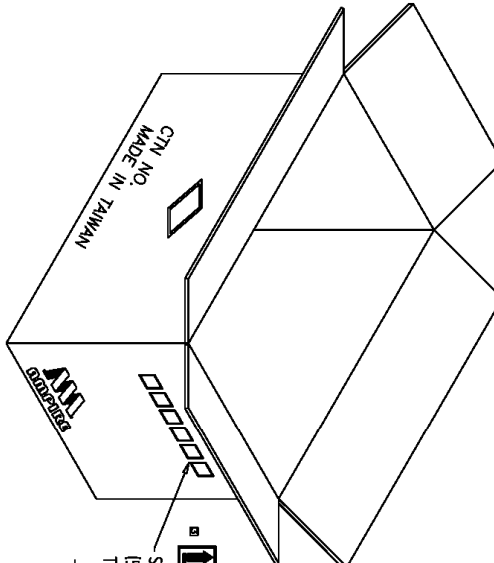

**REV. REVISION RECORD**  

0	NEW RELEASE	DH-I-SNOW
1	Renaine TF800600-41-0 to 800600L-00	HD-C-SNOW
2	臺灣天地板	HD-F-SNOW
3	Modify the outer box printing	HD-F-SNOW

**Size: L x W x H**  
 (527.0x356.0x26.0mm)  
 Tolerances:10.0  
**Big Box**

**TTITLE**  
 800600L-TD0 (10.4")

DWG. NO. *0909355SC	SHEET 1 of 1
---------------------	--------------

**Note:**

1. Bag = 1 PCS LCM
2. Big Box = 1 x 25 = 25 PCS LCM